

TOP

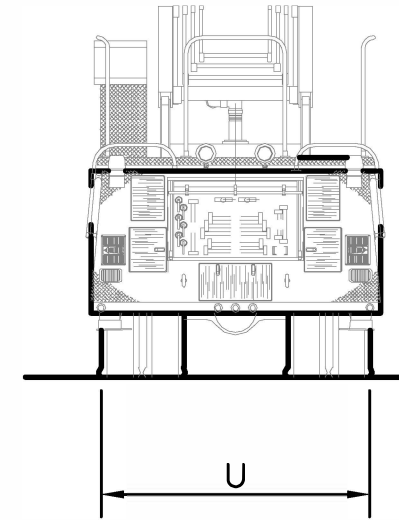

REAR

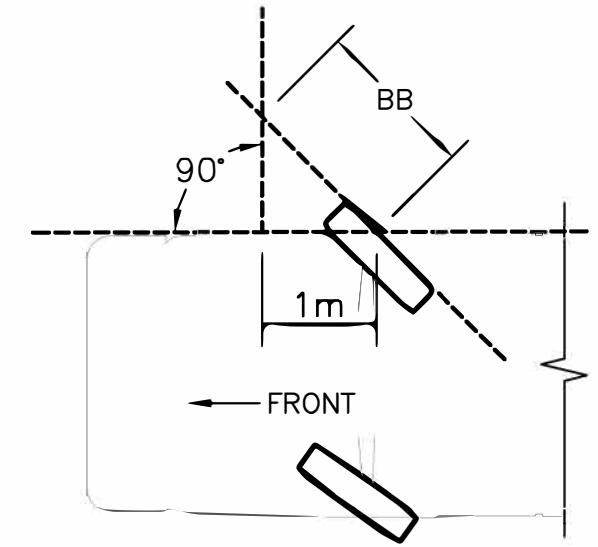

INSIDE TIRE STEERING ANGLE HYPOTENUSE LENGTH

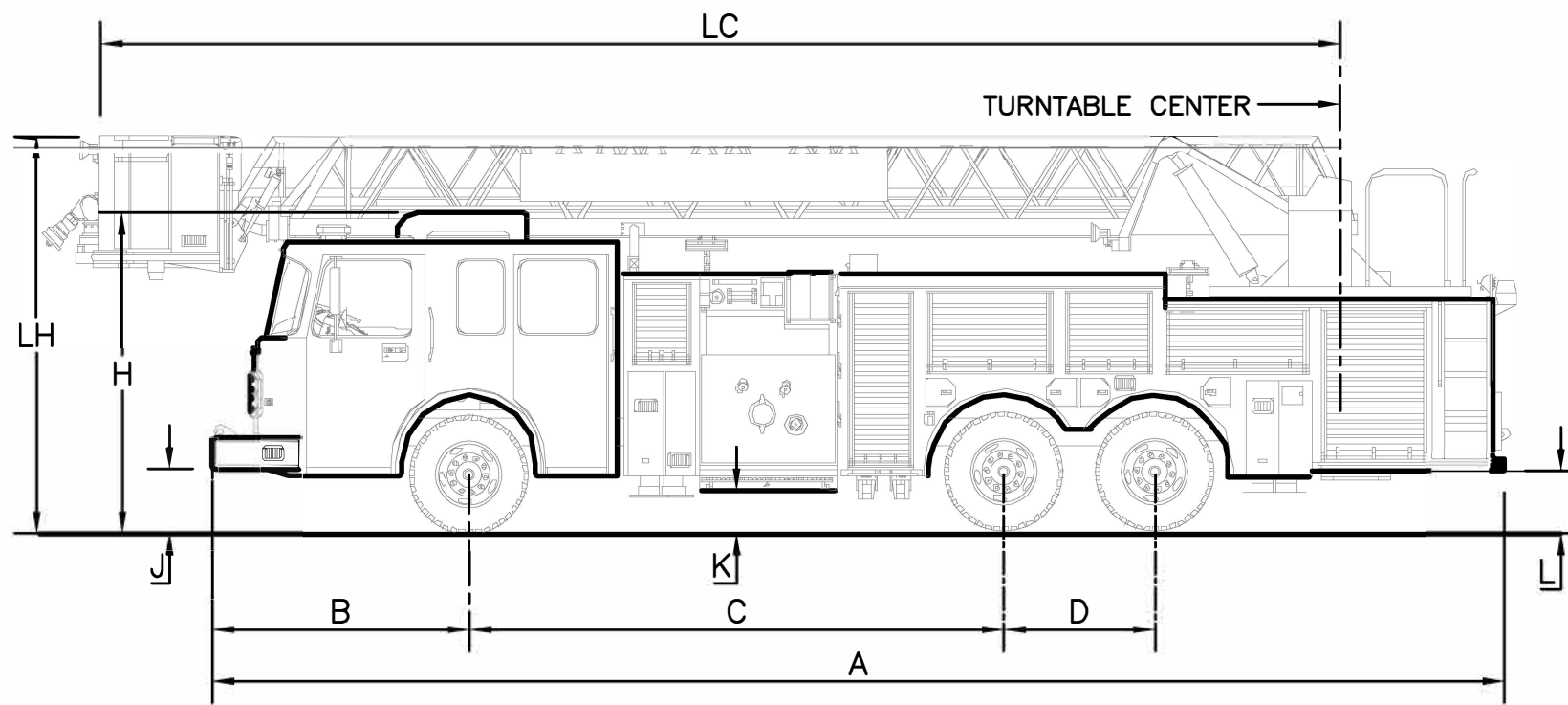

SIDE

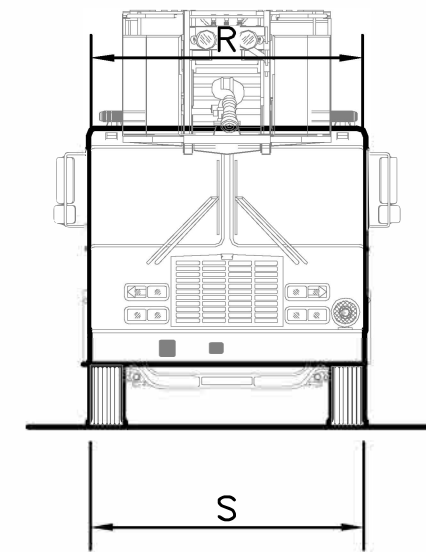

FRONT

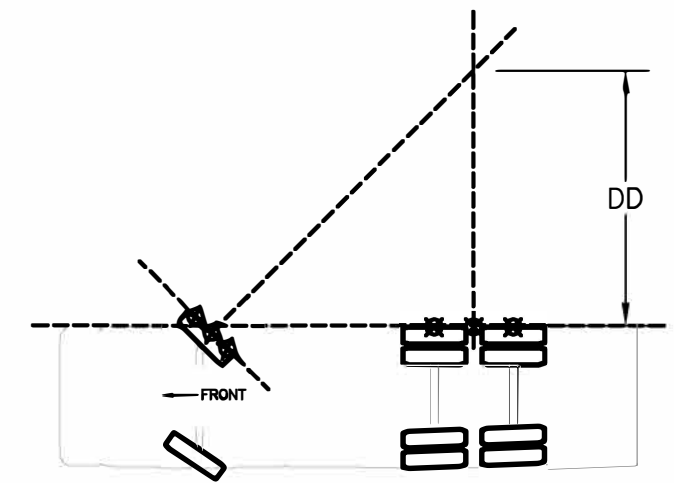

INNER TURN RADIUS

A	12,300 mm	S	2615 mm	LH	3700 mm	VEHICLE NAME:	Ladder L-2
B	2,342 mm	U	2620 mm	LC	12172 mm	VEHICLE TYPE:	PLATFORM, REAR MOUNT
C	6,285 mm	BB	1450 mm			MANUFACTURER:	Fort Garry Fire Trucks
D	1,452 mm	DD	5788 mm			VIN:	4S7AX2C916C05519544
H	2,910 mm	LL	11667 mm			CITY/COUNTY:	Swift Current
J	578 mm	LO	1180 mm			STATE/PROV.:	Sask
K	273 mm	LW	1460 mm	FRONT TIRE DIAMETER & WIDTH:		COUNTRY:	Canada
L	447 mm	BL	1435 mm	REAR TIRE DIAMETER & WIDTH:		DATA COLLECTION BY:	B Platoon
R	2,580 mm	BW	2532 mm	MIN. CURB-TO-CURB TURN RADIUS:		DATE OF COLLECTION:	April 14/2017
				10200 mm			